

Flail Mowers

Series No FM3072, FM3088 & FM4088

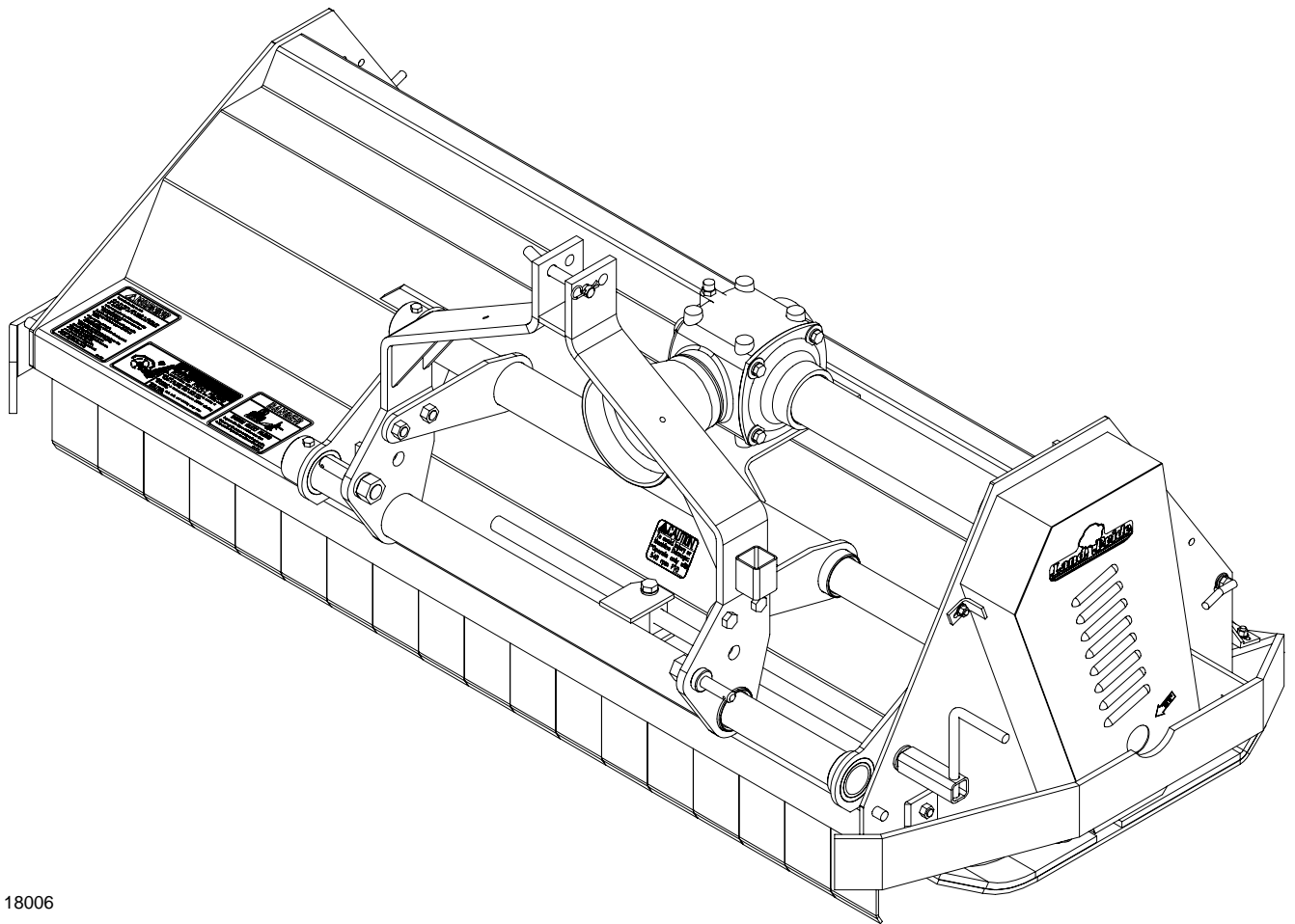

18006

309-106M Operator's Manual



Read the Operator's manual entirely. When you see this symbol, the subsequent instructions and warnings are serious - follow without exception. Your life and the lives of others depend on it!



© Copyright 2006 Printed 7/06/06

Cover photo may show optional equipment not supplied with standard unit.

Important Safety Information	1	Section 5: Specifications & Capacities . . .	15
Safety at All Times	1	Section 6: Features and Benefits	16
Look For The Safety Alert Symbol	1	Section 7: Troubleshooting	17
Safety Labels	4	Section 8: Appendix	18
Introduction	7	Torque Values Chart	18
Using This Manual	7	Warranty	19
Terminology	7		
Definitions	7		
Owner Assistance	7		
Serial Number Plate	7		
Further Assistance	7		
Section 1: Assembly and Set-up	8		
Tractor Requirements	8		
Hitch Assembly	8		
Tractor Hook-Up	9		
Driveline Installation	9		
Section 2: Operating Instructions	10		
Transporting	10		
Mowing Instructions	10		
Rake Teeth	10		
Operating Instructions	10		
Section 3: Adjustments	11		
Leveling the Mower	11		
Cutting Height Adjustment	11		
3-Point Hitch Adjustments	11		
Belt Tension	11		
Section 4: Maintenance and Lubrication	12		
Maintenance	12		
Service Mowing Knives (FM3072 & FM3088) & Ham-			
mers (FM4088)	12		
Knife or Hammer Replacement	12		
V-Belt Installation	12		
Storage	12		
Lubrication	13		
Driveline Shaft U-Joints	13		
Roller Bearing (Both Ends)	13		
Cutter Rotor Bearing (Both Ends)	13		
Gearbox	14		
Driveline Profiles	14		

© Copyright 2006 All rights Reserved

Land Pride provides this publication "as is" without warranty of any kind, either expressed or implied. While every precaution has been taken in the preparation of this manual, Land Pride assumes no responsibility for errors or omissions. Neither is any liability assumed for damages resulting from the use of the information contained herein. Land Pride reserves the right to revise and improve its products as it sees fit. This publication describes the state of this product at the time of its publication, and may not reflect the product in the future.

Land Pride is a registered trademark.

All other brands and product names are trademarks or registered trademarks of their respective holders.

Printed in the United States of America.

Important Safety Information

These are common practices that may or may not be applicable to the products described in this manual.

Safety at All Times

Thoroughly read and understand the instructions given in this manual before operation. Refer to the "Safety Label" section, read all instructions noted on them.

Do not allow anyone to operate this equipment who has not fully read and comprehended this manual and who has not been properly trained in the safe operation of the equipment.

- ▲ Operator should be familiar with all functions of the unit.
- ▲ Operate implement from the driver's seat only.
- ▲ Make sure all guards and shields are in place and secured before operating the implement.
- ▲ Do not leave tractor or implement unattended with engine running.
- ▲ Dismounting from a moving tractor could cause serious injury or death.
- ▲ Do not stand between the tractor and implement during hitching.
- ▲ Keep hands, feet, and clothing away from power-driven parts.
- ▲ Wear snug fitting clothing to avoid entanglement with moving parts.
- ▲ Watch out for wires, trees, etc., when raising implement. Make sure all persons are clear of working area.
- ▲ Turning tractor too tight may cause implement to ride up on wheels. This could result in injury or equipment damage.

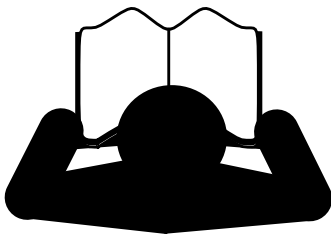

Look For The Safety Alert Symbol

The SAFETY ALERT SYMBOL indicates there is a potential hazard to personal safety involved and extra safety precaution must be taken. When you see this symbol, be alert and carefully read the message that follows it. In addition to design and configuration of equipment, hazard control and accident prevention are dependent upon the awareness, concern, prudence and proper training of personnel involved in the operation, transport, maintenance and storage of equipment.

Be Aware of Signal Words

A Signal word designates a degree or level of hazard seriousness. The signal words are:

DANGER

Indicates an imminently hazardous situation which, if not avoided, will result in death or serious injury. This signal word is limited to the most extreme situations, typically for machine components that, for functional purposes, cannot be guarded.

WARNING

Indicates a potentially hazardous situation which, if not avoided, could result in death or serious injury, and includes hazards that are exposed when guards are removed. It may also be used to alert against unsafe practices.

CAUTION

Indicates a potentially hazardous situation which, if not avoided, may result in minor or moderate injury. It may also be used to alert against unsafe practices.

For Your Protection

- ▲ Thoroughly read and understand the "Safety Label" section, read all instructions noted on them.

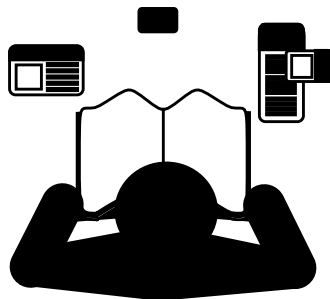

Shutdown and Storage

- ▲ Lower machine to ground, put tractor in park, turn off engine, and remove the key.
- ▲ Detach and store implements in a area where children normally do not play. Secure implement by using blocks and supports.

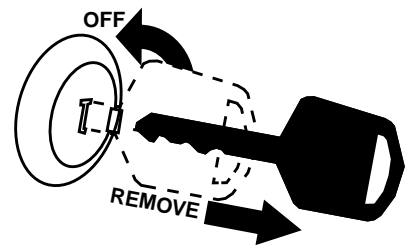

Important Safety Information

These are common practices that may or may not be applicable to the products described in this manual.

Use Safety Lights and Devices

- ▲ Slow moving tractors, self-propelled equipment, and towed implements can create a hazard when driven on public roads. They are difficult to see, especially at night.
- ▲ Flashing warning lights and turn signals are recommended whenever driving on public roads. Use lights and devices provided with implement.

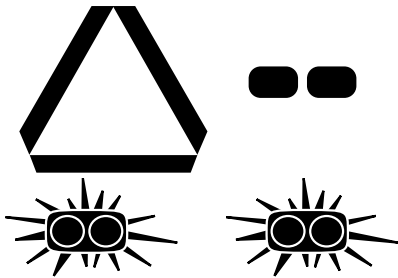

Transport Machinery Safely

- ▲ Comply with state and local laws.
- ▲ Maximum transport speed for implement is 20 mph. **DO NOT EXCEED.** Never travel at a speed which does not allow adequate control of steering and stopping. Some rough terrain require a slower speed.
- ▲ Sudden braking can cause a towed load to swerve and upset. Reduce speed if towed load is not equipped with brakes.

- ▲ Use the following maximum speed - tow load weight ratios as a guideline:
20 mph when weight is less than or equal to the weight of tractor.
10 mph when weight is double the weight of tractor.
- ▲ **IMPORTANT:** Do not tow a load that is more than double the weight of tractor.

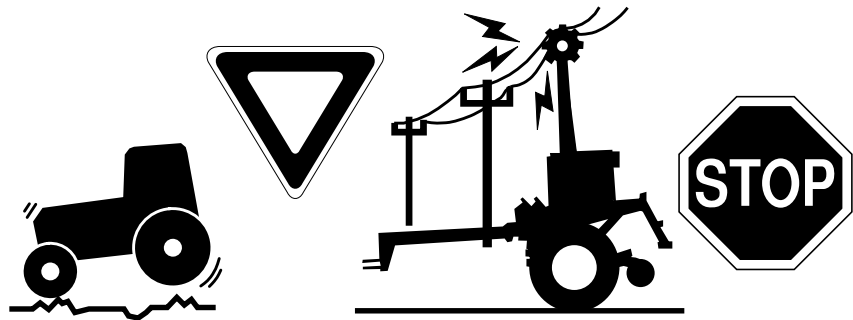

Practice Safe Maintenance

- ▲ Understand procedure before doing work. Use proper tools and equipment, refer to Operator's Manual for additional information.
- ▲ Work in a clean dry area.
- ▲ Lower the implement to the ground, put tractor in park, turn off engine, and remove key before performing maintenance.
- ▲ Allow implement to cool completely.
- ▲ Do not grease or oil implement while it is in operation.
- ▲ Inspect all parts. Make sure parts are in good condition & installed properly.
- ▲ Remove buildup of grease, oil or debris.
- ▲ Remove all tools and unused parts from implement before operation.



Important Safety Information

These are common practices that may or may not be applicable to the products described in this manual.

Prepare for Emergencies

- ▲ Be prepared if a fire starts.
- ▲ Keep a first aid kit and fire extinguisher handy.
- ▲ Keep emergency numbers for doctor, ambulance, hospital and fire department near phone.

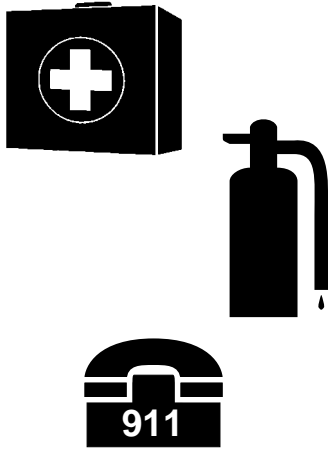
**Wear Protective Equipment**

- ▲ Protective clothing and equipment should be worn.
- ▲ Wear clothing and equipment appropriate for the job. Avoid loose fitting clothing.
- ▲ Prolonged exposure to loud noise can cause hearing impairment or hearing loss. Wear suitable hearing protection such as earmuffs or earplugs.
- ▲ Operating equipment safely requires the full attention of the operator. Avoid wearing radio headphones while operating machinery.

**Keep Riders Off Machinery**

- ▲ Riders obstruct the operator's view, they could be struck by foreign objects or thrown from the machine.
- ▲ Never allow children to operate equipment.

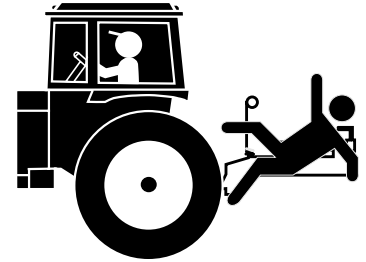

Important Safety Information

Safety Labels

Your Flail Mower comes equipped with all safety labels in place. They were designed to help you safely operate your implement. Read and follow their directions.

1. Keep all safety labels clean and legible.
2. Replace all damaged or missing labels. To order new labels go to your nearest Land Pride dealer or visit our dealer locator at landpride.com.
3. Some new equipment installed during repair requires safety labels to be affixed to the replaced component as

specified by Land Pride. When ordering new components make sure the correct safety labels are included in the request.

4. Refer to this section for proper label placement.

To install new labels:

- a. Clean the area the label is to be placed.
- b. Spray soapy water on the surface where the label is to be placed.
- c. Peel backing from label. Press firmly onto the surface.
- d. Squeeze out air bubbles with the edge of a credit card.

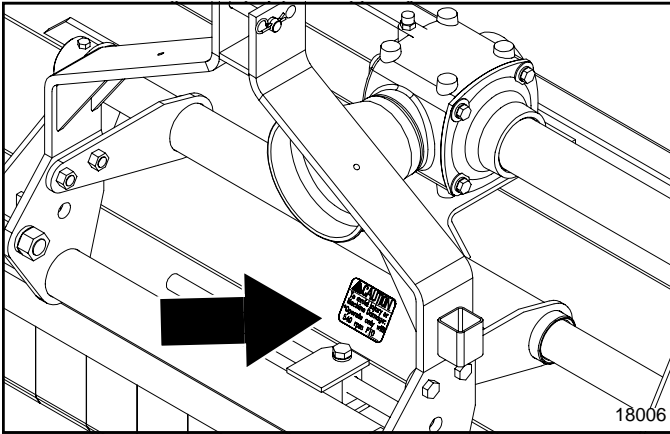

818-130C

Caution: To avoid injury

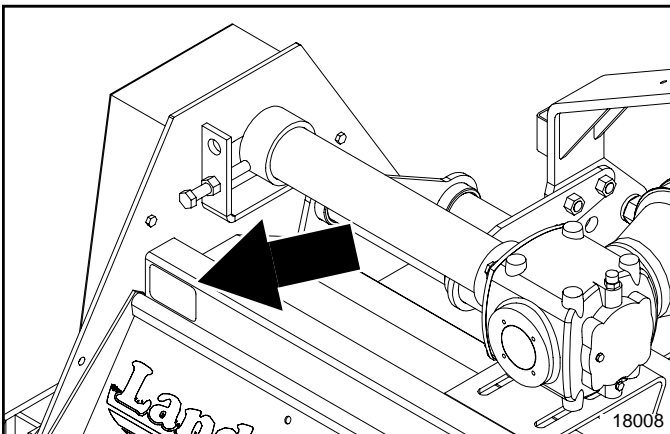

818-230C

Red Reflector (Both Sides)

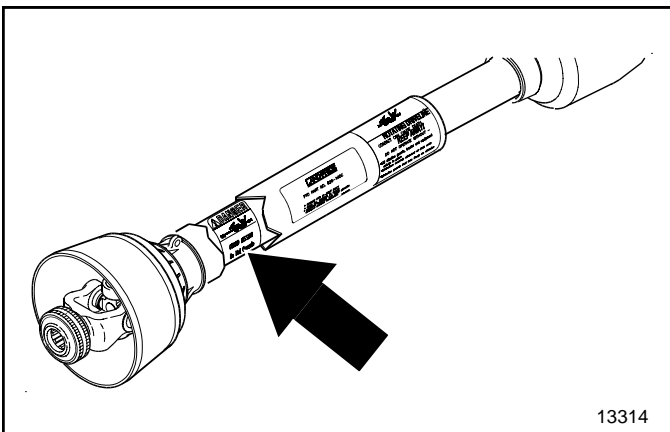

818-540C

Danger: Guard Missing

Important Safety Information

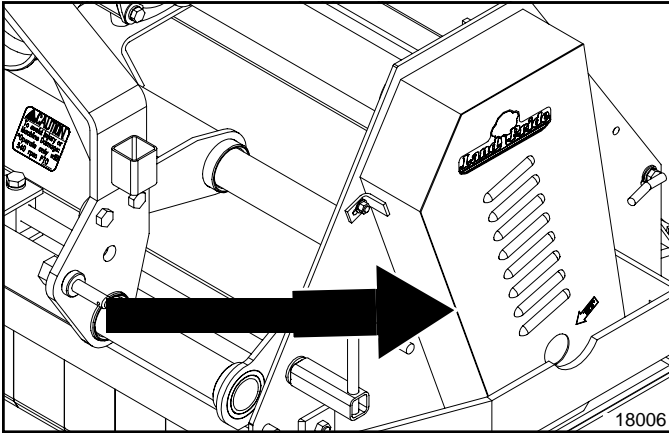

818-543C
 Danger: Guard Missing

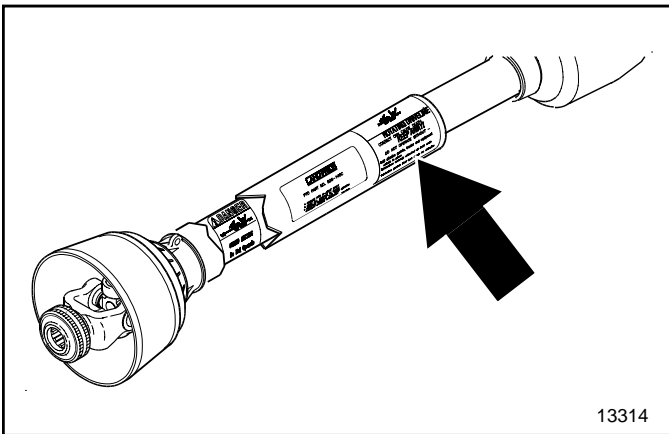

818-552C
 Danger: Rotating Driveline

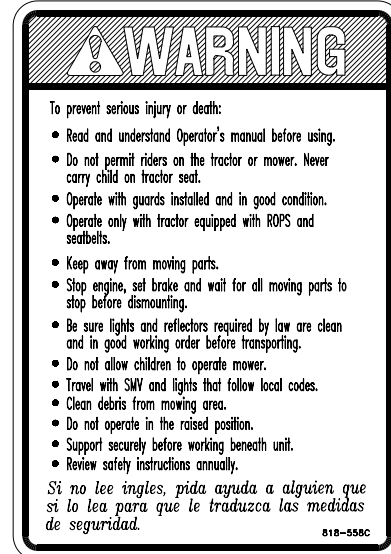
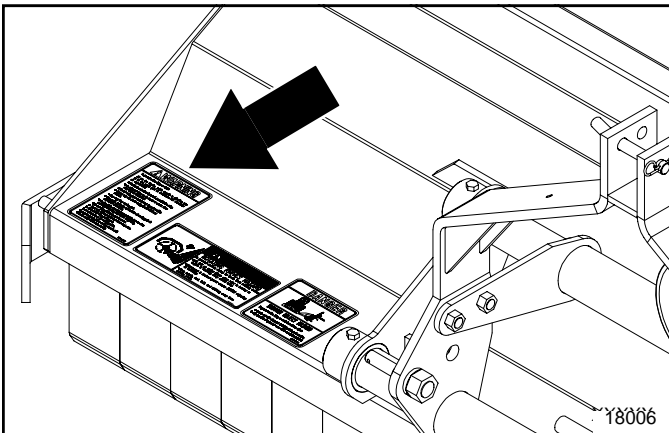

818-558C
 Warning: General

Important Safety Information

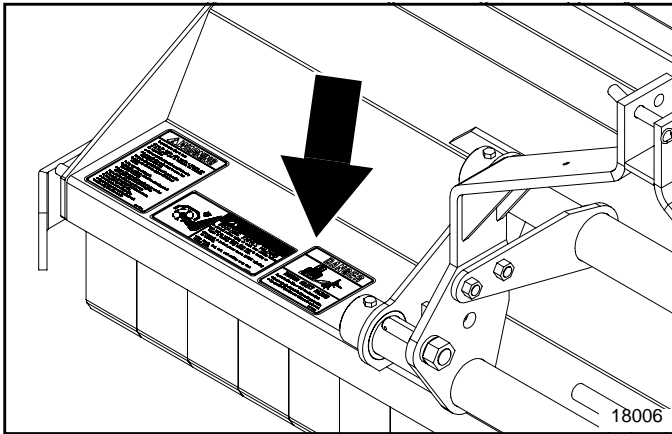

818-556C
Danger: Thrown Object

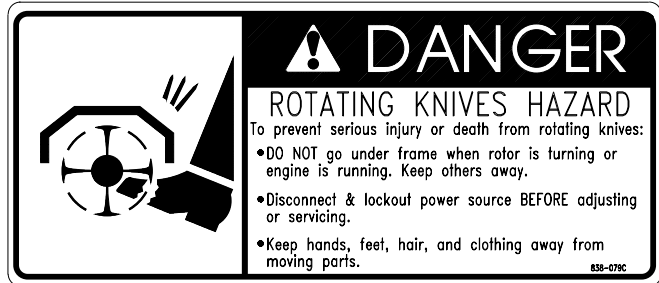
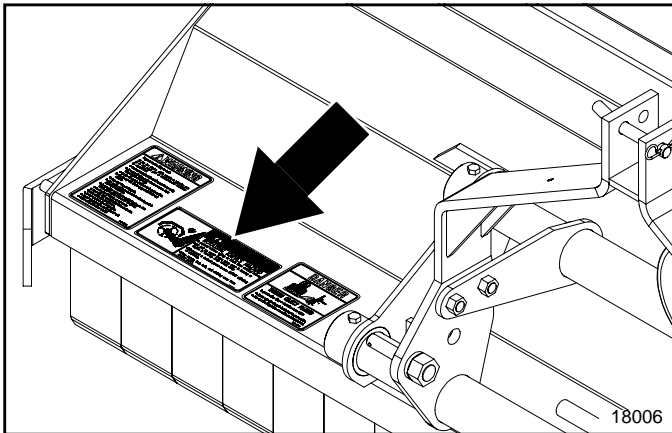

838-079C
Danger: Rotating
Knives Both sides

Introduction

Land Pride welcomes you to the growing family of new product owners. This implement has been designed with care and built by skilled workers using quality materials. Proper assembly, maintenance, and safe operating practices will help you get years of satisfactory use from the machine.

Using This Manual

- This Operator's Manual is designed to help familiarize you with safety, assembly, operation, adjustments, troubleshooting, and maintenance. Read this manual and follow the recommendations to help ensure safe and efficient operation.
- The information contained within this manual was current at the time of printing. Some parts may change slightly to assure you of the best performance.
- To order a new Operator's or Parts Manual contact your authorized dealer. Manuals can also be downloaded, free-of-charge from our website at www.landpride.com or printed from the Land Pride Service & Support Center by your dealer.

Terminology

"Right" or "Left" as used in this manual is determined by facing the direction the machine will operate while in use unless otherwise stated.

Definitions

NOTE: A special point of information that the operator must be aware of before continuing.

IMPORTANT: A special point of information related to its preceding topic. Land Pride's intention is that this information should be read and noted before continuing.

Owner Assistance

The Warranty Registration card should be filled out by the dealer at the time of purchase. This information is necessary to provide you with quality customer service.

If customer service or repair parts are required contact a Land Pride dealer. A dealer has trained personnel, repair parts and equipment needed to service the ?????.

The parts on your Flail Mower have been specially designed and should only be replaced with genuine Land Pride parts. Therefore, should your ????? require replacement parts go to your Land Pride Dealer.

Serial Number Plate

For prompt service always use the serial number and model number when ordering parts from your Land Pride dealer. Be sure to include your serial and model numbers in correspondence also. Refer to Figure 1 for the location of your serial number plate.

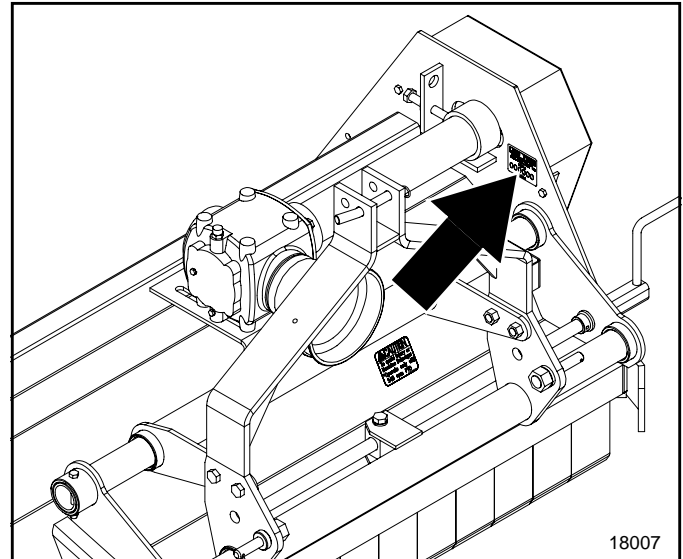

Serial Number Plate Location
Figure 1

Further Assistance

Your dealer wants you to be satisfied with your new Flail Mower. If for any reason you do not understand any part of this manual or are not satisfied with the service received, the following actions are suggested:

1. Discuss the matter with your dealership service manager making sure he is aware of any problems you may have and that he has had the opportunity to assist you.
2. If you are still not satisfied, seek out the owner or general manager of the dealership, explain the problem and request assistance.
3. For further assistance write to:

Land Pride Service Department
1525 East North Street
P.O. Box 5060
Salina, Ks. 67402-5060

E-mail address
lp servicedept@landpride.com

Tractor Requirements

This mower is designed with a 3-Point category I hitch. Tractor horse power rating should not exceed 80 PTO horse power.

NOTE: Ballast may need to be added to your tractor to maintain steering control. Refer to your tractor's operator manual to determine if additional ballast is needed.

Hitch Assembly

Refer to Figure 1-1:

The hitch is disassembled for ease in shipping.

1. Assemble hitch (#1) to the flail mower by inserting lower tube (#2) through the hitch.
2. Secure tube with bolt (#3) and lock nut (#4).
3. Secure hitch with bolts (#5) and nuts (#6) as shown.
4. Place block (#8) between the two plates welded to the tube on hitch (#1).
5. Install adjustment rod (#7) through mower frame and adjustment block (#8).
6. Secure adjustment block (#8) with bolt (#9) and lock washer (#10).
7. Tighten all hardware. Refer to "**Torque Values Chart for Common Bolt Sizes**" Page 18.

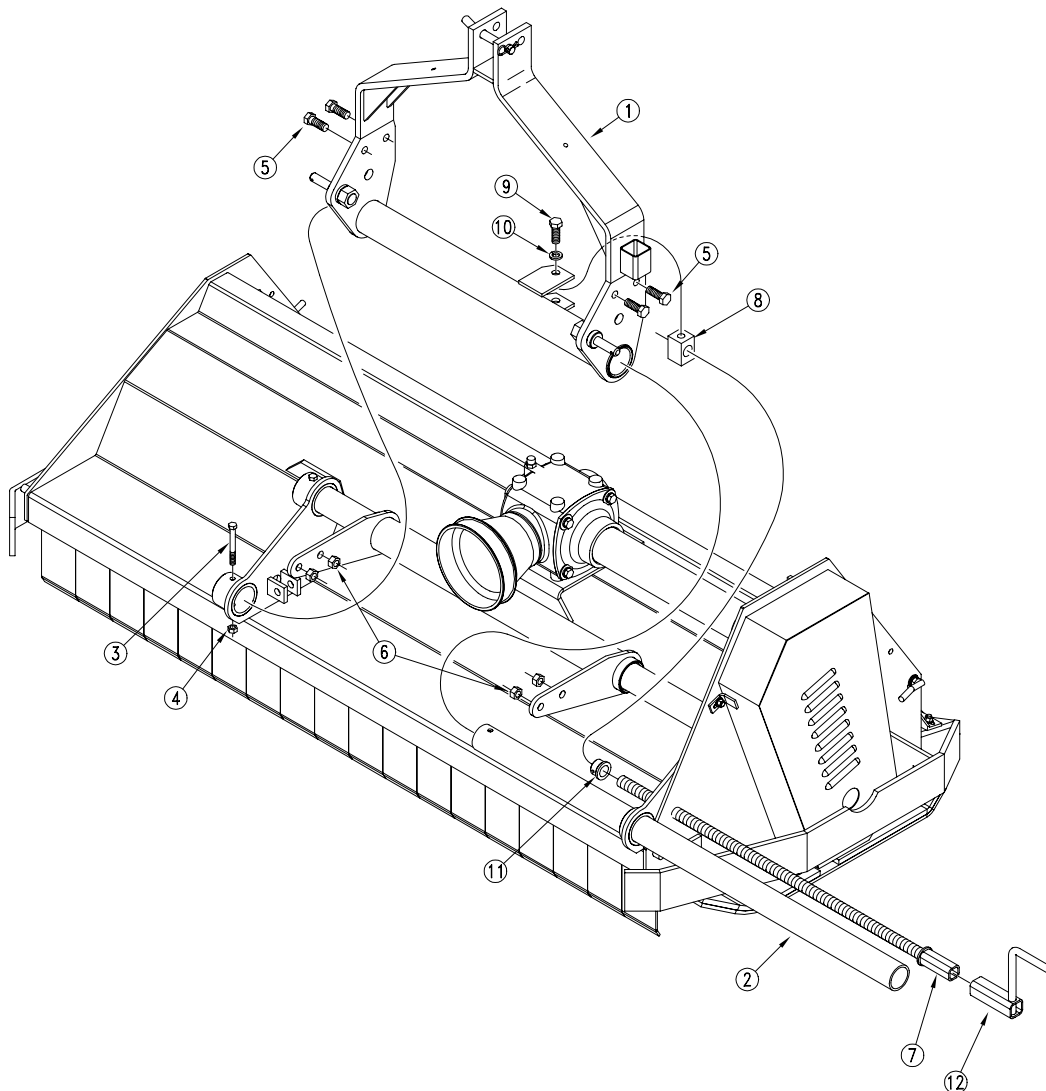

**Hitch Assembly
Figure 1-1**

18010

Section 1: Assembly and Set-up

Tractor Hook-Up

1. Be certain that tractor draw bar will not interfere. Move draw bar ahead or remove if required. Draw bar should also be checked for clearance when unit is being raised for the first time.
2. Align lower link arms of tractor to hitch clevises on mower. Insert lower hitch pins into lower ball swivels and attach linch pins.
3. Attach tractor top link to upper floating hitch on mower with pin supplied. Secure with lock pin.
4. Adjust tractor top link in or out to place upper hitch pin vertically above or slightly behind lower hitch pins as shown in Figure 1-2, to allow mower flotation. The mower should be run with the back 15 degrees lower than the front.
3. Driveline should now be moved back and forth to insure that it is secure on the PTO shaft of the tractor and mower gearbox.
4. Attach chain from the driveline shield to one of the upper hitch braces to ensure that the shield does not rotate.
5. Should driveline require shortening:
 - a. Hold the half-shafts next to each other in the shortest working position and mark them.
 - b. Shorten inner and outer guard tubes equally.
 - c. Shorten inner and outer sliding profiles by the same length as the guard tubes.
 - d. Proper overlap is a minimum of one-half the length of each tube, with both tubes being of equal length.
 - e. Round off all sharp edges and remove burrs. Grease sliding profiles.

Driveline Installation

1. Slide driveline end with extended safety cone over splined shaft of gearbox and secure with attaching device.
2. Slide driveline over tractor's splined PTO shaft and secure with locking device of driveline.

CAUTION

Tractor PTO shield and all mower guards must be in place at all times during operation!

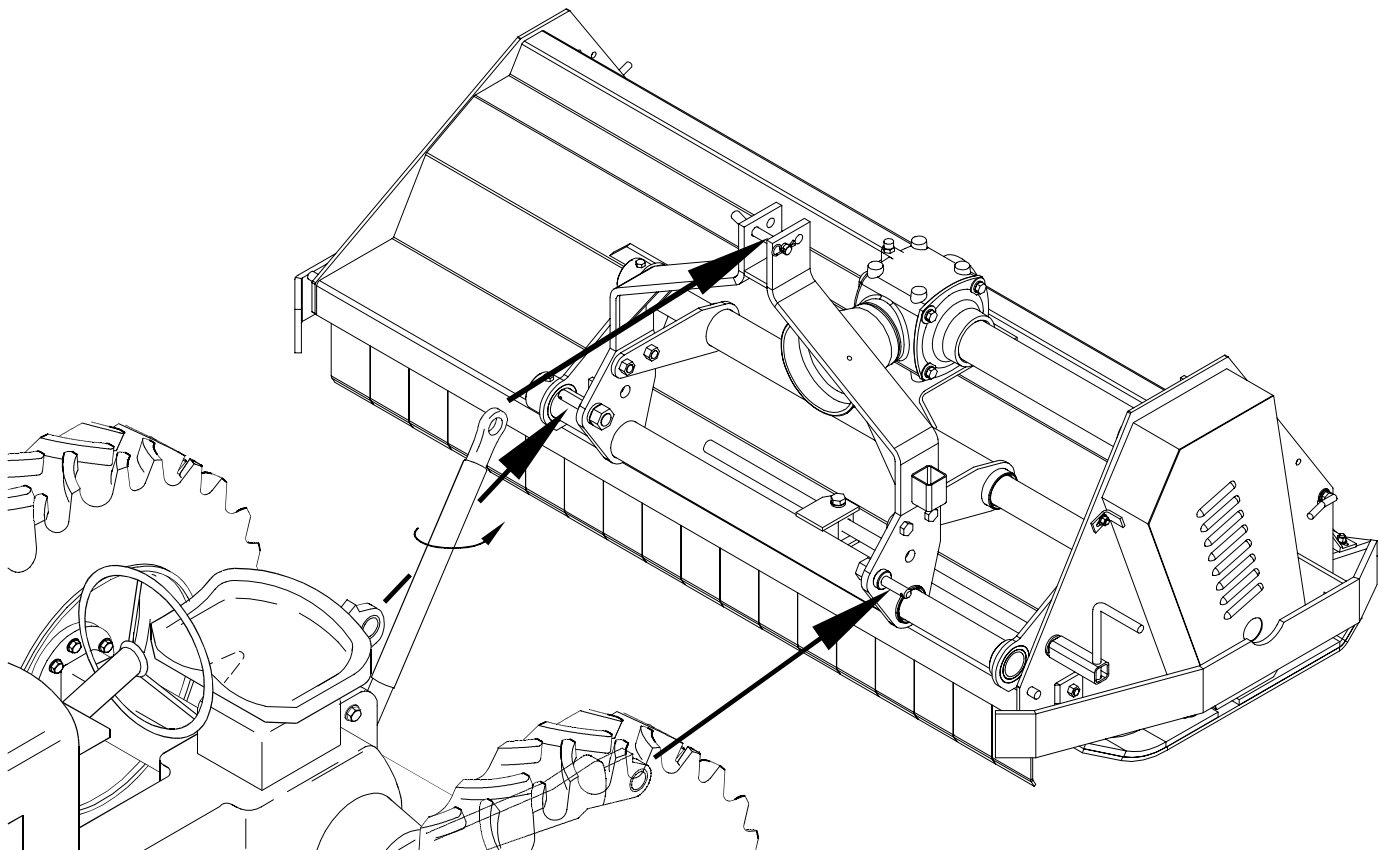

Tractor Hook-Up
Figure 1-2

18011

Transporting

NOTE: Always disengage PTO before raising mower to transport position.

6. When raising the mower to transport position, be sure that driveline does not contact tractor or mower. Adjust and set the tractor's 3-point hitch lift height so that the driveline does not contact mower deck in the fully raised position.
7. Be sure to reduce tractor ground speed when turning, leaving enough clearance so that the mower does not contact obstacles such as buildings, trees or fences.
8. Select a safe ground travel speed when transporting from one area to another. When traveling on roadways, transport in such a way that faster moving vehicles may pass safely.
9. When traveling over rough or hilly terrain, shift tractor to a lower gear.

CAUTION

When traveling on public roads, whether at night or during the day, use accessory lights and devices for adequate warning to operators of other vehicles. Comply with all Federal, State, and local laws.

Mowing Instructions

1. Clear area to be mowed of objects and debris that might be picked up and thrown by the mower blades.
2. Grass is best cut when it is dry. Mowing wet grass can cause plugging resulting in grass clumps behind the mower.
3. Grass should be mowed frequently as shorter clippings deteriorate faster.
4. If mowing extremely tall grass, it is best to raise cutting height and mow the area, then lower cutting height and mow a second time at the desired height.

Rake Teeth

The FM4088 comes equipped with adjustable rake teeth. The teeth allow the continued cutting/chopping of material before final dispersal.

CAUTION

When mowing in sandy soil areas, wear may occur to the mower knives from sand erosion. Frequent inspection should be made and knives replaced if damaged.

Operating Instructions

Proper servicing and adjustments are the key to the long life of any machine. With careful and systematic inspection of the mower, costly maintenance, time and repair can be avoided.

Before beginning to mow, the following inspection should be performed:

1. Check oil level in gearbox. Refer to "**Section 4: Maintenance and Lubrication**" on page 14.
2. Check that all plugs in gearbox have been replaced and tightened properly.
3. Be sure all mower knives, bolts and nuts are tight.
4. Be certain all guards and shields are in place and secure.
5. Grease driveline shaft and all other grease fittings.
6. Clear area to be mowed of rocks, branches and other foreign objects.
7. Lower mower to ground. Set tractor throttle at approximately 1/4 open. Engage PTO to start blades rotating.
8. Operate with 540 rpm PTO tractor.
9. At first begin mowing at a slow forward speed and shift up until the desired speed is achieved - maintaining 540 PTO rpm.
10. Mower knives will cut better at a faster blade speed than at reduced throttle.
11. After mowing the first 50 feet, stop and check to see that the mower is adjusted properly.
12. **Do not** make sharp turns or attempt to back up while mower is on the ground.
13. **Do not** engage PTO with mower in the fully raised position. **Do not** engage PTO at full throttle.

Section 3: Adjustments

Leveling the Mower

NOTE: Tractor and mower should be on level ground.

Leveling can be adjusted at the tractor's 3-point arms and center link.

Cutting Height Adjustment

Refer to Figure 3-1:

The machine's cutting height depends upon the position of the rear roller.

1. Remove the bolts that fix the roller on both sides.
2. Lift or lower both sides of roller in equal measurements.
3. Replace bolts and re-tighten.

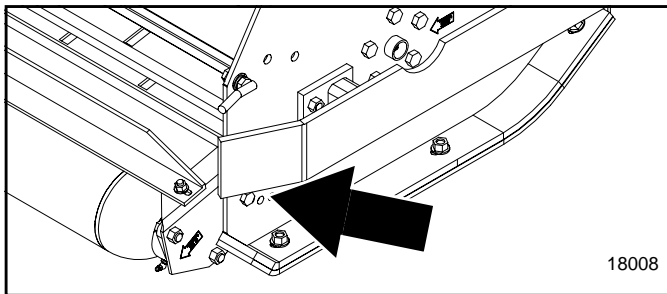

Cutting Height
Figure 3-1

3-Point Hitch Adjustments

The 3-point hitch system on this mower has been designed for front to back flotation when mowing on uneven terrain. Adjust tractor's top center link to place the upper hitch pin vertically above or slightly behind the lower hitch pins. The mower should be run with the back 15 degrees lower than the front.

The hitch can also be adjusted from side to side by turning the adjustment handle. Turn handle until you have achieved your desired location. Refer to Figure 3-2.

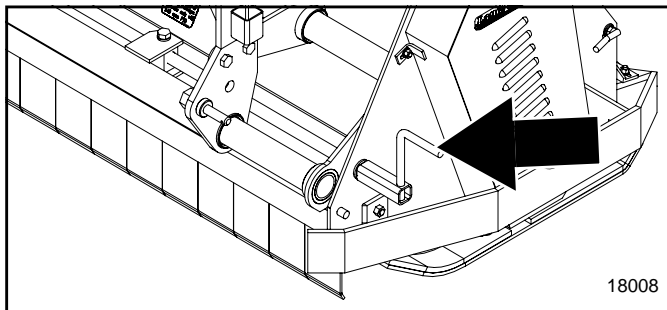

Hitch Adjustment
Figure 3-2

CAUTION

Engage parking brake, shut off tractor, remove key and disengage PTO before making any height adjustments!

Belt Tension

CAUTION

Belt drive system under spring tension; use care to avoid bodily harm!

The Belt tension should be checked after the first 20 hours of use. And then every 40 hours of use.

1. To check tension apply approximately 22 pounds of pressure half way between the pulleys. There should be approximately 3/8" of deflection. Tension on the belt can be adjusted with the belt tension bolt. Turn the bolt until desired tension is achieved. When the belt has the correct tension the gearbox should be adjusted so that the gearbox extension is running straight (parallel) with the flail mower. Loosen bolts at the bottom of the gearbox and move gearbox until gearbox extension is running straight. Refer to Figure 3-3.

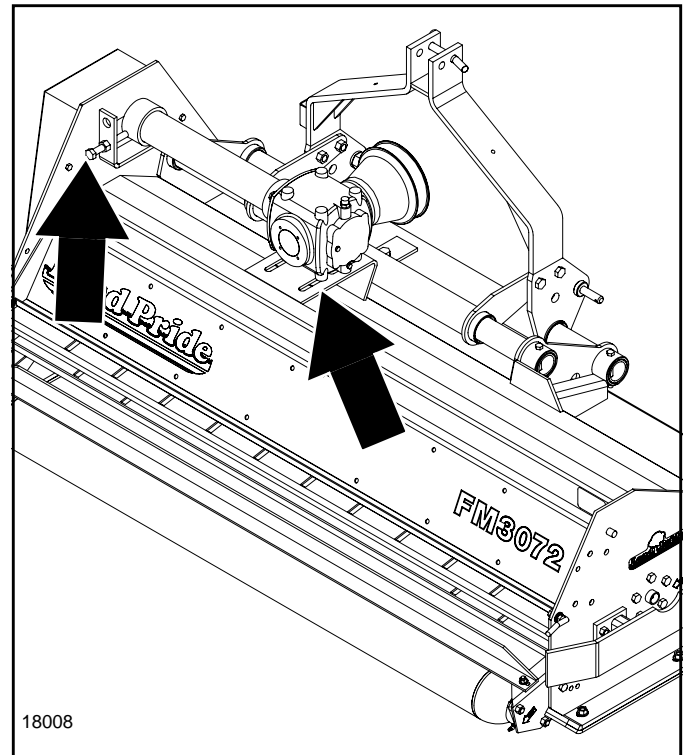

Belt Tension
Figure 3-3

2. If there is excessive deflection the belts should be replaced. Refer to "Belt Installation" Figure 5-1.
3. Excessive tension on the belt may lead to premature failure of belt and drive components.

WARNING

Excessive tension on the belt may lead to premature failure of belt and drive components. Excessive tension on the belt may also lead to a safety hazard to the operator or bystanders.

Section 4: Maintenance and Lubrication

Maintenance

Proper servicing and adjustment is the key to the long life of any implement. With careful and systematic inspection, costly maintenance, time and repair can be avoided.

CAUTION

For safety reasons, each maintenance operation must be performed with tractor PTO disengaged, mower lowered completely to ground and tractor engine shut off with ignition key removed.

- After using the mower for several hours, check all bolts to be sure they are tight and check drive belt tension. Refer to *Belt Tension* in "Section 3: Adjustments" on page 11.
- Lubricate items as listed under "Lubrication" on page 13.
- Replace any worn, damaged or illegible safety labels by obtaining new labels from your Land Pride Dealer. Information about labels is located under *Safety Labels* in "Important Safety Information" on page 1.

Service Mowing Knives (FM3072 & FM3088) & Hammers (FM4088)

Knife or Hammer Replacement

IMPORTANT: Make sure that the knife or hammer is the same length as the others on the mower. This will keep the rotor rotation balanced.

IMPORTANT: Replace knives with Land Pride knives or hammers only.

1. Remove bolt and nut.
2. Remove old knife or hammer.
3. Install new knife or hammer and existing bolt.
4. Secure with nut. Tighten nut to proper torque as listed in the "Torque Values Chart" on page 18.

V-Belt Installation

Refer to Figure 5-1:

CAUTION

Belt drive system under spring tension; use care to avoid bodily harm!

1. Remove belt guard fender and belt cover.
2. Disengage belt tension by loosening belt tension bolt until belt can be removed.
3. With tension relieved from belt remove old belt from pulleys.
4. Tighten belt tension bolt. See "**Belt Tension**" on page 11.
5. Reinstall belt guard (#2) and belt guard fender (#1).

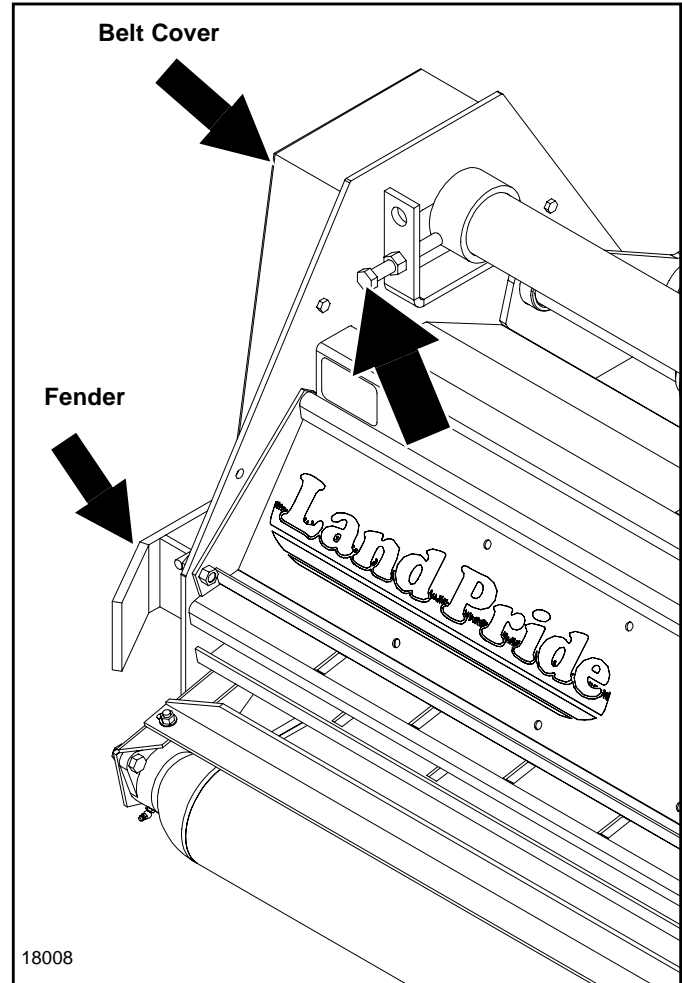

Belt Installation
Figure 5-1

Storage





At the end of the working season or when the mower will not be used for a long period, it is good practice to clean off any dirt or grease that may have accumulated on the mower and any of moving parts.

1. Clean as necessary.
2. Check knives for wear and replace if necessary, see *Service Mowing Knives or Hammers*, this section.
3. Inspect mower for loose, damaged or worn parts and adjust or replace as needed.
4. Lubricate as noted in the *Lubrication* portion of this section starting on page 13.
5. Store unit inside if possible for longer life.



Repaint parts where paint is worn or scratched to prevent rust. Ask your dealer for aerosol Land Pride Beige touch-up paint #821-011C.

Section 4: Maintenance and Lubrication

Lubrication

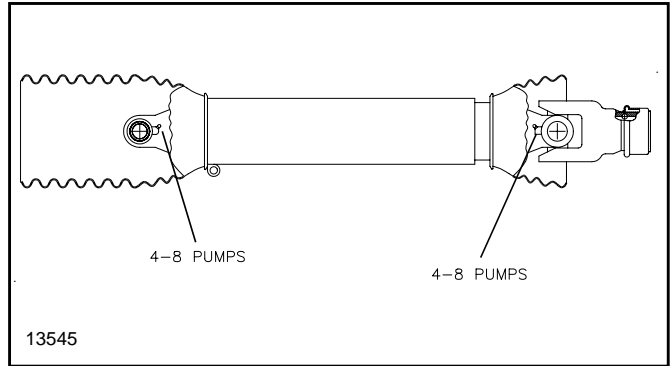
Lubrication Legend	 Multi-purpose spray lube	 Multi-purpose grease lube	 Multi-purpose oil lube	 Intervals in hours at which lubrication is required





	 25 Hours
---	--

Driveline Shaft U-Joints

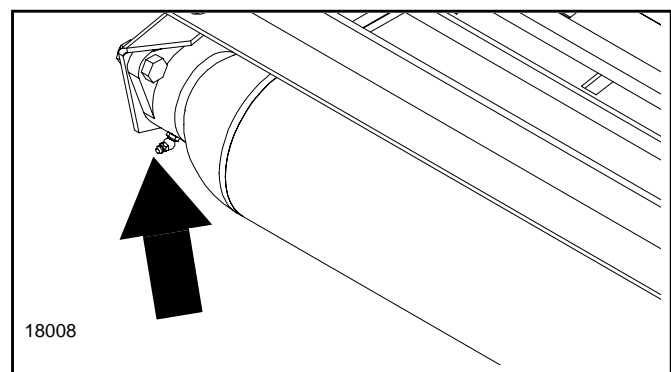
Type of Lubrication: Multi-purpose Grease





	 25 Hours
---	--

Roller Bearing (Both Ends)

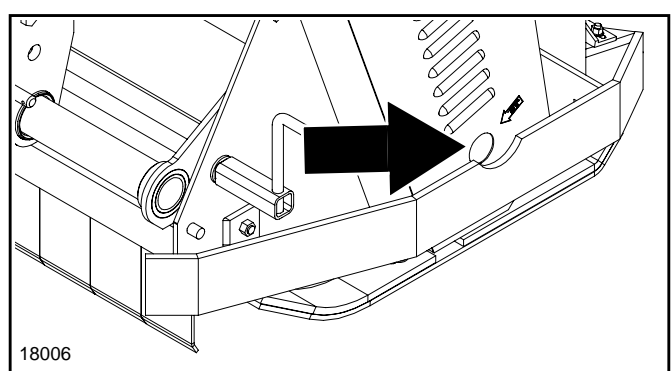
Type of Lubrication: Multi-purpose Grease



	 25 Hours
---	--

Cutter Rotor Bearing (Both Ends)

Type of Lubrication: Multi-purpose Grease

Section 4: Maintenance and Lubrication

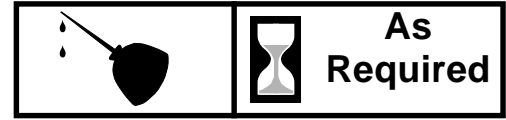
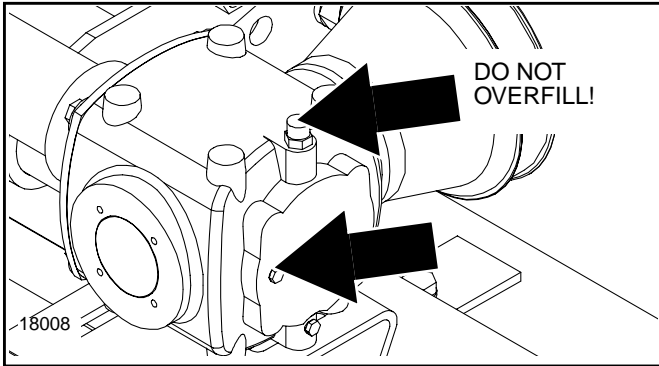

Gearbox

Type of Lubrication: SAE 90W Gear Lube

Check oil level in gearbox by removing the plug located on the right hand side. Oil should be level with bottom of plug hole. Add oil if necessary by removing top fill plug and side plug. Add oil until it flows from side plug hole.

Do not overfill!

Should your gearbox require service, take it to your LAND PRIDE dealer.

IMPORTANT: Mower should be level when checking oil in gearbox!

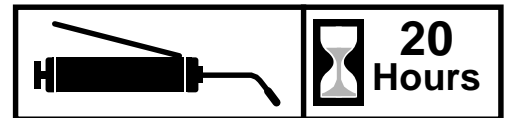
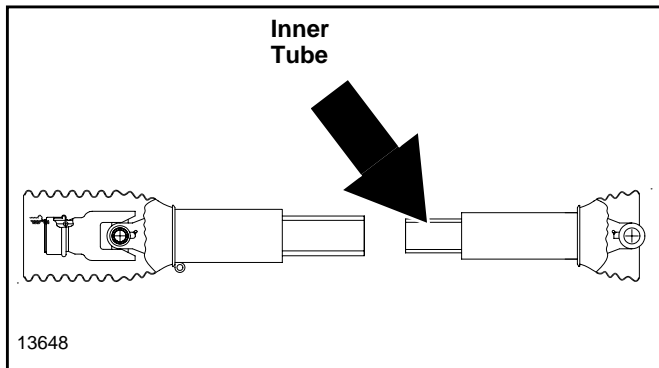

Driveline Profiles

Type of Lubrication: Multi-purpose Grease

Section 5: Specifications & Capacities

FM30 & FM40 Series Flail Mowers			
	FM3072	FM3088	FM4088
Cutting Width	72"	88"	88"
Overall Width	80"	96"	96"
Height	45"		
Depth	43"		
Weight	1014 lbs.	1122lbs.	1142 lbs.
Cutting Height	1/2 - 6"		
Deck Material Thickness	3/16"		
Knives	Fine cut		Hammer
Rotor Shaft Speed	1900 RPM		
Rotor Diameter	5 1/2"		
Rotor Rotation	Reverse		
Knife Tip Speed	8705 fpm		
Number of Knives/Hammers	40	48	24
Offset Hitch	7 3/4" Left & Right, Screw-Type		
Driveline	Cat. 4		
Gearbox Rating	80 HP		
Rear Roller Diameter	5 1/2"		
Rake Teeth	NA		13 each

FM30 & FM40 Series Flail Mowers

Features	Benefits
Key widths	30 Series: 72", 88"; 40 Series: 88"
Gearbox HP Rating	35 - 80 HP
7 3/4" Left & right-screw type offset hitch	Easily offset the hitch for roadsides or getting under tree limbs.
ACME threads on offset	ACME threads are deeper allowing for easy screwing adjustment.
Gearbox Warranty	One year on all components.
540 RPM cast iron gearbox with over-running clutch	Enables the rotor to free swing to a stop when the tractor PTO has been turned off.
1/2" – 6" Cutting height	Variable cutting heights for many uses.
1" Cutting capacity (30 Series) 2" Cutting capacity (40 Series)	Cut saplings when used in a rough setting. 40 Series is good for chopping up tree trimmings.
Fine cut knives (30 Series) Forged hammer knives (40 Series)	Heavy enough to cut 1" material, yet fine enough to groom a yard. Forged hammers are just right for chopping up prunings up to 2" thick, but will also groom grass in a very acceptable manner.
Brush rake teeth (40 Series)	The adjustable brush rake teeth continually push prunings into the knife path for repeated chopping action.
5 1/2" Rotor diameter	Large rotor is able to take rough conditions.
Reverse rotor rotation	Brings the cut material up and over which allows it to be dispersed more evenly.
Cat. 4 driveline	Heavy-duty driveline matches up with HP range as well as potential conditions.
3 'C' Section belts	'C' Section belts have more surface to pulley contact, and fits deeper in the groove.
3/16" Deck thickness	Allows the mower to handle rough conditions.
Baffles on top inside of deck	Keeps the cut material from clumping together, ensuring an even distribution of clippings.
Hinged rear gate	Can be opened for easier discharge in heavy conditions, or left closed for greater mulching capabilities.
Height adjusting roller	Rear height adjusting roller with greaseable bearings and tapered ends to prevent gouging during turns.
Scrapers	Standard scrapers on rear height adjusting roller, keeps roller clean for consistent cutting height
High knife tip speed	Knife tip speed of 8,705 fpm for cleaner cut.

Section 7: Troubleshooting

Problem	Solution
 CAUTION <i>Do not try to clean rear discharge area when mower is running. Bodily harm may occur!</i>	
Belt slipping	Unplug and clean mower deck.
	Remove belt guard shields and clean sheaves.
	Replace belt
Patches of uncut grass	Mow at full throttle (540 PTO rpm), check PTO speed and tractor engine.
	Shift transmission to a lower gear.
	Tighten belts.
	Replace missing knives or hammers.
Excessive vibration	Replace knives or hammers
	Replace drive belt.
	Replace pulleys or align.
	Remove belt guard shields & clean debris from belt area & sheaves.
Gearbox noisy	Check lubricant level.
Knives scalping grass	Raise cutting height by adjusting roller.
	Change mowing pattern.
	Reduce speed turns.
Uneven cut	Shift to a lower gear.
	Level mower.
	Replace missing knives or hammers
Tractor loaded down by mower	Mow at full throttle (540 PTO rpm).
	Shift to a lower gear.
	Clean mower.



Torque Values Chart													
Bolt Size (Inches)	Bolt Head Identification						Bolt Size (Metric)	Bolt Head Identification					
	Grade 2		Grade 5		Grade 8			Class 5.8		Class 8.8		Class 10.9	
in-tpi ¹	N · m	ft-lb ³	N · m	ft-lb	N · m	ft-lb	mm x pitch	N · m	ft-lb	N · m	ft-lb	N · m	ft-lb
1/4" - 20	7.4	5.6	11	8	16	12	M 5 X 0.8	4	3	6	5	9	7
1/4" - 28	8.5	6	13	10	18	14	M 6 X 1	7	5	11	8	15	11
5/16" - 18	15	11	24	17	33	25	M 8 X 1.25	17	12	26	19	36	27
5/16" - 24	17	13	26	19	37	27	M 8 X 1	18	13	28	21	39	29
3/8" - 16	27	20	42	31	59	44	M10 X 1.5	33	24	52	39	72	53
3/8" - 24	31	22	47	35	67	49	M10 X 0.75	39	29	61	45	85	62
7/16" - 14	43	32	67	49	95	70	M12 X 1.75	58	42	91	67	125	93
7/16" - 20	49	36	75	55	105	78	M12 X 1.5	60	44	95	70	130	97
1/2" - 13	66	49	105	76	145	105	M12 X 1	90	66	105	77	145	105
1/2" - 20	75	55	115	85	165	120	M14 X 2	92	68	145	105	200	150
9/16" - 12	95	70	150	110	210	155	M14 X 1.5	99	73	155	115	215	160
9/16" - 18	105	79	165	120	235	170	M16 X 2	145	105	225	165	315	230
5/8" - 11	130	97	205	150	285	210	M16 X 1.5	155	115	240	180	335	245
5/8" - 18	150	110	230	170	325	240	M18 X 2.5	195	145	310	230	405	300
3/4" - 10	235	170	360	265	510	375	M18 X 1.5	220	165	350	260	485	355
3/4" - 16	260	190	405	295	570	420	M20 X 2.5	280	205	440	325	610	450
7/8" - 9	225	165	585	430	820	605	M20 X 1.5	310	230	650	480	900	665
7/8" - 14	250	185	640	475	905	670	M24 X 3	480	355	760	560	1050	780
1" - 8	340	250	875	645	1230	910	M24 X 2	525	390	830	610	1150	845
1" - 12	370	275	955	705	1350	995	M30 X 3.5	960	705	1510	1120	2100	1550
1-1/8" - 7	480	355	1080	795	1750	1290	M30 X 2	1060	785	1680	1240	2320	1710
1 1/8" - 12	540	395	1210	890	1960	1440	M36 X 3.5	1730	1270	2650	1950	3660	2700
1 1/4" - 7	680	500	1520	1120	2460	1820	M36 X 2	1880	1380	2960	2190	4100	3220
1 1/4" - 12	750	555	1680	1240	2730	2010							
1 3/8" - 6	890	655	1990	1470	3230	2380							
1 3/8" - 12	1010	745	2270	1670	3680	2710							
1 1/2" - 6	1180	870	2640	1950	4290	3160							
1 1/2" - 12	1330	980	2970	2190	4820	3560							

¹ in-tpi = nominal thread diameter in inches-threads per in.
² N · m = newton-meters
³ ft-lb = foot pounds
⁴ mm x pitch = nominal thread diameter in millimeters x thread pitch

Torque tolerance + 0%, -15% of torquing values. Unless otherwise specified use torque values listed above.

Section 8: Appendix

Warranty

Land Pride warrants to the original purchaser that this Land Pride product will be free from defects in material and workmanship beginning on the date of purchase by the end user according to the following schedule when used as intended and under normal service and conditions for personal use.

Overall Unit and Driveline: One year Parts and Labor

Gearbox: One year on all components.

Blades and Belts: Considered wear items.

This Warranty is limited to the replacement of any defective part by Land Pride and the installation by the dealer of any such replacement part, and does not cover common wear items. Land Pride reserves the right to inspect any equipment or parts which are claimed to have been defective in material or workmanship.

This Warranty does not apply to any part or product which in Land Pride's judgment shall have been misused or damaged by accident or lack of normal maintenance or care, or which has been repaired or altered in a way which adversely affects its performance or reliability, or which has been used for a purpose for which the product is not designed. Misuse also specifically includes failure to properly maintain oil levels, grease points, and driveline shafts.

Claims under this Warranty should be made to the dealer which originally sold the product and all warranty adjustments must be made through an authorized Land Pride dealer. Land Pride reserves the right to make changes in materials or design of the product at any time without notice.

This Warranty shall not be interpreted to render Land Pride liable for damages of any kind, direct, consequential, or contingent to property. Furthermore, Land Pride shall not be liable for damages resulting from any cause beyond its reasonable control. This Warranty does not extend to loss of crops, any expense or loss for labor, supplies, rental machinery or for any other reason.

No other warranty of any kind whatsoever, express or implied, is made with respect to this sale; and all implied warranties of merchantability and fitness for a particular purpose which exceed the obligations set forth in this written warranty are hereby disclaimed and excluded from this sale.

This Warranty is not valid unless registered with Land Pride within 30 days from the date of purchase by the end user.



Corporate Office: P.O. Box 5060
Salina, Kansas 67402-5060 USA
www.landpride.com
